

Helping young
Aussies square
up to cancer

BANDANNA DAY GUIDE

SELLING BANDANNAS

#BandannaDayAu



Our values and commitments

Diversity and Inclusion

Cancer doesn't discriminate and neither do we. We welcome people with diverse sexualities, gender identities and intersex variations and from all cultures, backgrounds and abilities.



Acknowledgement of Country

Canteen acknowledges Aboriginal and Torres Strait Islander peoples as the Traditional Custodians of this land. We pay respect to Elders past, present and future. We are committed to providing inclusive and appropriate support for Aboriginal and Torres Strait Islander young people, their kin and community impacted by cancer. Indigenous Australians are respectfully advised this resource may contain images, names or stories of people who have passed away.

Ngalaya (Dharawal for ally or friend in battle), is an artwork commissioned by Canteen created by Kamilaroi and Jerrinja woman and artist Jasmine Sarin.



Contents

- Thank you from Chloe 5
- Top fundraising tips..... 6
- The impact you're making..... 7
- Ways to style your bandanna 8
- Setting up your box..... 10
- Returning funds and stock 11



“My bandanna is a symbol of the many things that help keep me going – music, friends and family. Let the painful moments fall around you like confetti and never forget the things that matter to you most.”

Chloe,
Canteen youth ambassador



Thank you from Chloe

When I was 9 years old, my beloved grandfather was diagnosed with prostate cancer.

He moved in with our family while he went through several rounds of treatment including surgery, chemotherapy and radiotherapy – staying with us until he sadly passed away when I was 17.

Seeing my grandfather slowly deteriorate and then being there for him while he took his final breath will forever be etched in my memory. For a long time, it was hard to even bring it to the surface without crying.

Shortly after I turned 18 and while still processing the loss of my grandfather, Mum was diagnosed with breast cancer after a lump was found during a routine mammogram.

I was an emotional mess at school and felt incredibly isolated. It was hard to focus and I just wanted to be with my mum. I was terrified that she would die too.

I reached out to Canteen shortly after Mum's diagnosis. I needed support to get me through, especially going into my final year at school.

Canteen helped me not only come to terms with my mum's diagnosis, but they also helped me grieve the death of my grandfather, which I didn't even know they could do.

Canteen provided me with counselling sessions and introduced me to a supportive community of other young people going through similar challenges to help ease my feelings of isolation.

Everyone just 'gets it' at Canteen. They also helped me go to online and in-person events which have helped me establish lifelong friendships and given me the opportunity to do things that I have never done.

It's not just all about being sad, we're laughing and enjoying life with each other.

Chloe, youth ambassador

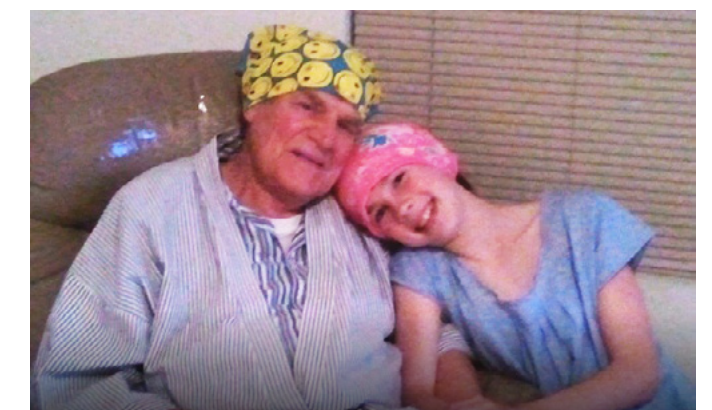

Top fundraising tips

How you can make the most of your Bandanna Day fundraiser.



Kickstart your fundraising and make a personal donation on your fundraising page. Others will follow your lead.



Share far and wide! Post details of your Bandanna Day fundraiser, and how people can purchase their bandanna from you, on your social media accounts and via texts and emails.



Tell your story by sharing your personal connection with friends, family, colleagues and local businesses. Sharing details about why you're fundraising can be incredibly powerful and will show people how important their support is.



Ask for support from your workplace or school. There might be an upcoming event you can sell your bandannas at, or you could create your own.



Share weekly updates of how many bandannas you have left to sell. Why not ask for your fundraising page link to be shared in the next school / company newsletter? This will help you spread the word about your fundraiser.



Say thank you to everyone who purchases a bandanna from you and let them know you're grateful for their support.

We've got heaps of handy downloadable resources on our [website](#) to help you get the most out of your Bandanna Day event.

Check them out here



The impact you're making

Every year, 23,000 young people aged 12-25 are impacted by cancer in Australia.

Every dollar raised from Bandanna Day helps Canteen provide practical and emotional support to help young people explore their feelings about cancer and connect with their peers going through similar experiences. If a young person has been diagnosed with cancer, we also provide youth-specific treatment teams to support them on their journey.

\$15



can provide youth friendly resources to help a young person struggling with their diagnosis

\$45



can help a young person access life-changing support 24/7 through Canteen Connect

\$65



can help a young person attend a drop in event at their local Canteen office

\$120



can help a young person work through their cancer experience with a specialist counsellor

\$270



can help a young person attend one of our in-person programs

\$700



can send a young person on a locally organised 3-day program



Ways to style your bandanna

Wear it on your head, around your neck, or on your arm — everyone has their own bandanna-style.



Alice Band

Fashionable and functional. The Alice Band is for those looking to make a sleek and stylish fashion statement.

1. First, take your bandanna and fold in half diagonally to form a triangle.
2. Starting from the point, fold backwards by 4cm as many times as necessary until you meet the opposite side.
3. You should now have a long, thick strip.
4. Centre the bandanna at the base of your hairline and lift both ends upwards, passing behind your ears. Tie the ends in a single knot on top of your head.



Wristband

By wrapping them around your wrists you can turn them into the ultimate style accessory that adds colour and flair to your cuffs.

1. Take your bandanna and fold in half diagonally to form a triangle.
2. Starting from the long side, fold back by 6cm as many times as necessary until you meet the opposite point.
3. You should now have a long, thick strip.
4. Wrap the bandanna around your wrist and tie.



Scrunchie

The best bandannas for the scrunchie style are the premium range bandannas.

1. Take your bandanna and fold in half diagonally to form a triangle.
2. Starting from the long side, fold back by 6cm as many times as necessary until you meet the opposite side.
3. You should now have a long, thick strip.
4. Tie this around your ponytail as many times as you like to get your desired look.



Classic

This is the no fuss approach. It's simple and effective and gets the job done.

1. Take your bandanna and fold in half diagonally to form a triangle.
2. Put the long edge of the bandanna to your forehead, placing it as high or low as you like.
3. Smooth the body of the triangle back over your head, with the point falling by the nape of your neck.
4. Bring the ends of the bandanna to the back of the head, overlapping the triangle tip and tie in a single knot



Headband

Always trendy, always hip, forever cool. It's the choice of Wimbledon champions and thousands of Aussies this Bandanna Day.

1. Take your bandanna and fold in half diagonally to form a triangle.
2. Starting from the long side, fold back by 6cm as many times as necessary until you meet the opposite side.
3. You should now have a long, thick strip.
4. Centre the headband on your forehead and tie the ends behind your head in a single knot.



Neck

Whether you're perfectly stylish, or want to channel your inner cowboy, the necktie is a rebellious classic

1. Take your bandanna and fold in half diagonally to form a triangle.
2. Starting from the long side, fold backwards by 3cm twice towards the point.
3. Wrap around your neck and tie in a single knot at the back.



Share a pic of you in your bandanna in our #BandannaDayAu Facebook group or tag @CanteenAus and #BandannaDayAu on your social media posts.

How do you wear yours?



Setting up your box

1. Unfold the top and side flaps to reveal stock

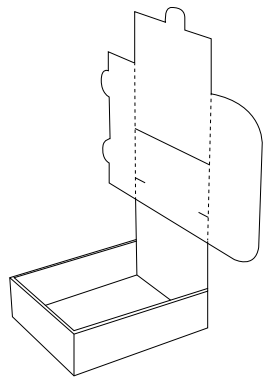

2. Remove the side flaps

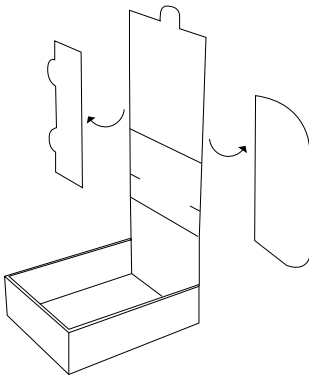

3. Fold over the top flap, then fold the lid along the double crease and tuck behind the bandannas

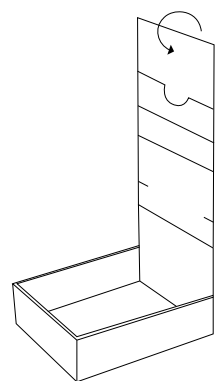

Start Selling!

Visit your fundraising dashboard for your personalised QR code and posters to help make selling a breeze.

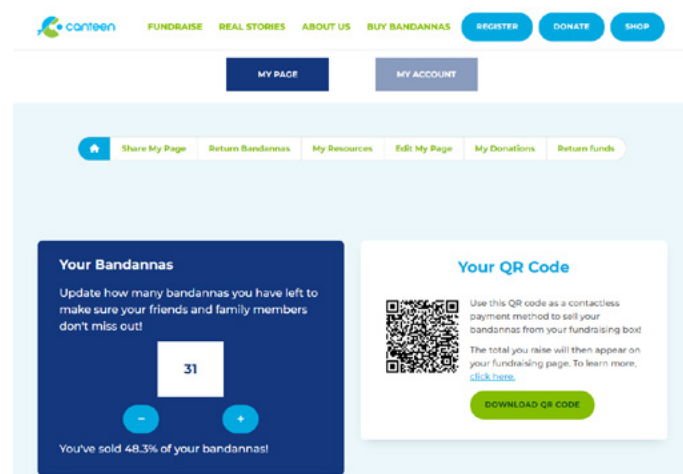

Returning funds and stock

Depositing funds

Depositing the funds you've raised is simple. If you've either collected funds via bank transfer or have already deposited cash donations to your own account, you deposit them back to us via a direct bank transfer or you can send us a cheque.



Deposit via electronic transfer

Bank: NAB

Account Name: Canteen Australia

BSB: 082 001

Account number: 518 822 412

Reference number: This starts with NBD24 and can be found at the top of your welcome letter and next to your name on your fundraising page.

ABN: 77 052 040 516

Once you have completed the transfer, please send a remittance advice or screenshot of your payment to ibd@canteen.org.au



Deposit by cheque

Send a cheque to us at:

**Canteen Bandanna Day Returns
Reply Paid 3821
Sydney NSW 2001**

Please remember to include your reference number (this starts with NBD24 and can be found at the top of your welcome letter and next to your name on your fundraising page) on the back of the cheque.



Returning unsold stock

On your fundraising dashboard you'll find a return paid postage label and stock form. Print these off and send back with your remaining bandannas (no need to return the box this can be recycled in your yellow bin).

Attached the reply paid label to the package and drop off at any Australia Post box. It will come back to us with no charge to you.

Please ensure you fill out the 'return bandannas' slip with the number of bandannas you are returning and send this back with the unsold stock. This makes it easier for us to reconcile your order.

**Canteen Bandanna Day Returns
Reply Paid 87022
Erskine Park NSW 2759**

Have questions about fundraising this Bandanna Day? Check out bandannaday.org.au/faqs or contact us at ibd@canteen.org.au

**Thank you for helping
young people square
up to cancer**

1800 639 614

bandannaday.org.au

nbd@canteen.org.au

**Connect with us
on our socials**



[canteen_au](https://www.instagram.com/canteen_au)



[canteen_australia](https://www.tiktok.com/@canteen_australia)



[CanteenAus](https://www.facebook.com/CanteenAus)



[CanteenAustralia](https://www.youtube.com/CanteenAustralia)



[canteen-australia](https://www.linkedin.com/company/canteen-australia)

#BandannaDayAu

